

MAT14PR

MAYTAG® COMMERCIAL
ENERGY ADVANTAGE™
TOP-LOAD WASHER



LEGENDARY MAYTAG DEPENDABILITY

Maximizing your equipment investment for over a half century.



Built with optional non-metered design.

FOR YOUR CUSTOMERS:

- Proven Cleaning Performance
- Extra-Large Lid And Tub Opening
- Easy-To-Use One Touch Cycle Selection
- Flexible Wash Options
- Time Remaining Display
- No Need To Carry Quarters

FOR YOUR OPERATION:

- The Most-Efficient, Best-Cleaning Top-Load Washer From Maytag
- Super Cycle Option Increases Revenue
- Self-Diagnostic Feature Cuts Service Costs And Minimizes Downtime
- Front Access For Easier Self-Service
- Accu Trac® Audit System With Two-Way Data Communication
- Debit Card Compatibility
- Advanced Computer Trac® Controls Allow For Easy Programming

BUILT-TO-LAST™ FEATURES:

- Premium Porcelain-Enamel Top
- Beltless Design
- Dependable Direct Drive Transmission
- Self Cleaning Pump
- Best Warranty In The Business



LAUNDRY SOLUTIONS
YOU CAN *DEPEND* ON.

REDUCES WATER USAGE **BY 25%***

visit maytagcommerciallaundry.com
or call 800-662-3587

* Compared to Maytag® top-load washers manufactured before 2005.



OUR COMMITMENT TO DEPENDABLE QUALITY

At Maytag, we believe durable goods should remain just that. That's why every Maytag® product is constructed of the highest-quality materials and with the utmost in precision craftsmanship. It's also why we stand behind our equipment with solid service and support from our professional Maytag laundry suppliers. Simply put, when you choose Maytag® products, you ensure your peace of mind.



MAT14PR MAYTAG® COMMERCIAL ENERGY ADVANTAGE™ TOP-LOAD WASHER

Maytag® Energy Advantage™ Top-Load Washer

MICROPROCESSOR CARD READER-READY

WASHER SPECIFICATIONS	
MODEL	MAT14PR
MOTOR	
Single-phase, reversible, thermoprotected, high torque	•
HP (kw)	½ (.37)
APPROXIMATE WATER USAGE — gallons (liters)	
Average hot water usage per cycle	3.7 (14)*
Average total water usage per cycle	23.2 (87.8)*
ELECTRICAL RATING	
Voltage	120V/60 Hz
BREAKER/FUSE REQUIREMENT	
Amps	15
CYLINDER	
Volume — cu. ft. (liters)	2.5 (70.8)
Diameter — in. (mm)	18.4 (468)
Depth — in. (mm)	17.8 (454)
LID OPENING	
In. (mm)	18 (457)
EXTRACT SPEED	
Maximum rpm	640
Maximum g-force	107
OPERATING PRESSURE	
Psi (bar)	20-100 (1-8)
INLET HOSE LENGTH	
Ft. (m)	4.5 (1.37)
DRAIN HOSE LENGTH	
Ft. (m)	4.4 (1.34)
APPROXIMATE WEIGHT	
Crated — lbs. (kg)	165 (74.8)
Uncrated — lbs. (kg)	151 (68.5)

* Average based on JI testing with factory preset cycles.

See specific instructions for proper installation. Because of continuous product improvement, Maytag reserves the right to change specifications without notice.

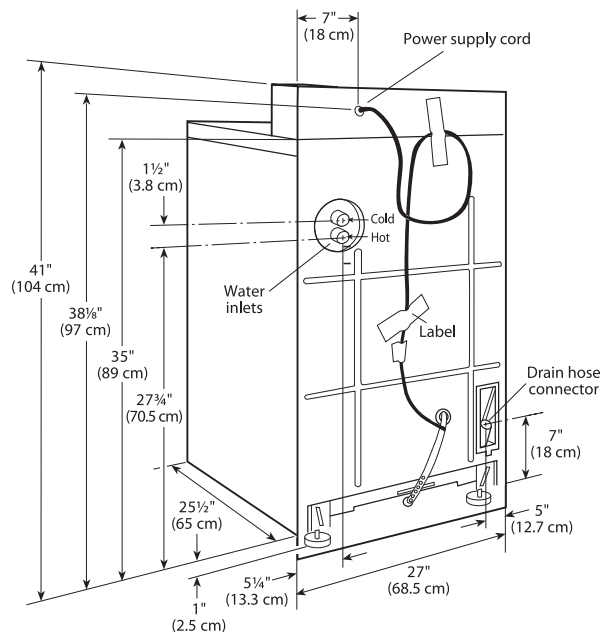

NEW YORK CITY
M.E.A.



THE BEST WARRANTY IN THE BUSINESS — 5 YEARS ON ALL PARTS

For a period from the date of original purchase through the time listed above, the designated parts that fail in normal commercial use will be repaired or replaced free of charge for the part itself, with the owner paying all other costs, including labor, transportation and customs duty. Chemical damage is excluded from all warranty coverage. See complete warranty for details.