



LAUNDRY **SOLUTIONS**
YOU CAN *DEPEND* ON.

MAYTAG® COMMERCIAL ENERGY ADVANTAGE™ TOP-LOAD WASHER

MAT12PRL

MORE ENERGY-SAVING SOLUTIONS THAN ANY OTHER BRAND

Maytag built the first appliance ever to receive the ENERGY STAR® label. Today we offer more high-efficiency laundry appliances than any other brand — from energy-efficient dryers to highly efficient ENERGY STAR®-qualified washers — to help you save money and build profits.



FOR YOUR RESIDENTS:

- Improved Cleaning Performance
- Debit Cards Mean No Loose-Change Hassles
- Vacuum Fluorescent Display Panel
- Extra-Large Lid And Tub Opening For Easy Loading And Unloading

FOR YOUR FACILITY:

- The Most-Efficient, Best-Cleaning Top-Load Washer From Maytag
- Thermistor Water Valve Regulates Water Temperature To Cut Energy Costs
- Super Cycle Option Increases Revenue
- Self-Diagnostic Feature Cuts Service Costs And Minimizes Downtime
- Front Access For Easier Self-Service
- Accu Trac® Audit System With Two-Way Data Communication
- Debit Card Compatibility

BUILT-TO-LAST™ FEATURES:

- Premium Porcelain Top
- Quad Coat™ Cabinet Protection
- Dependable Drive® Transmission
- Poly-Pump™ Self-Cleaning Polypropylene Pump Can't Rust

* Compared to previous Maytag® Dependable Care top-load washer.

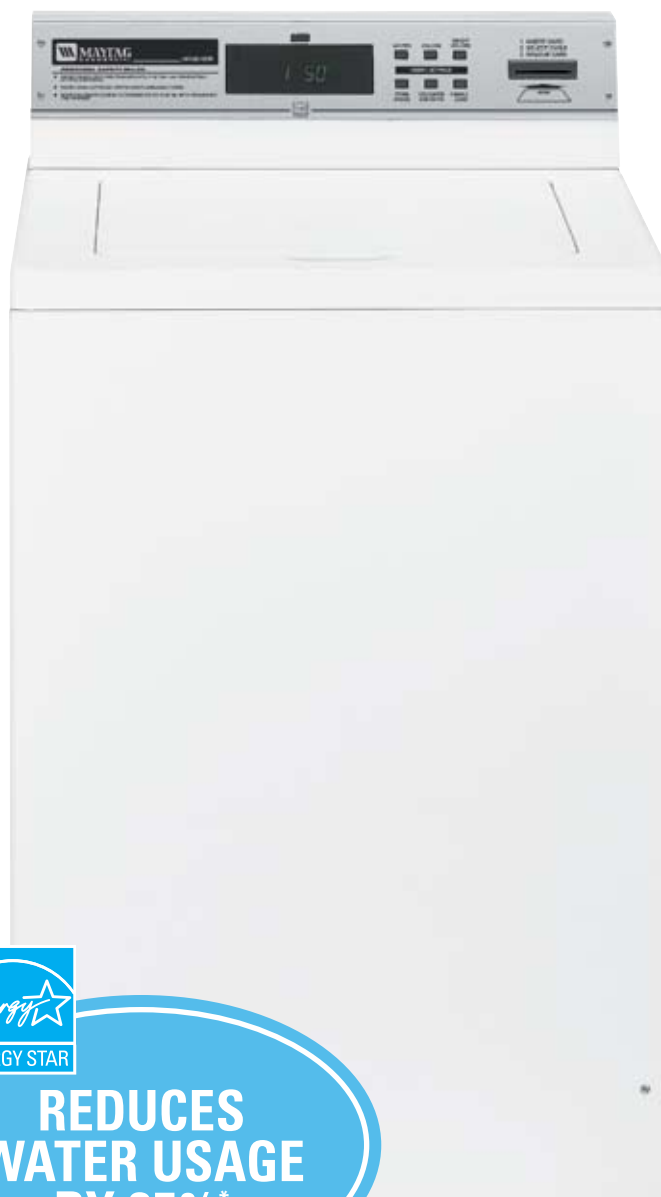

**REDUCES
WATER USAGE
BY 25%***

Maytag® Energy Advantage™ Top-Load Washer

DEBIT CARD-READY

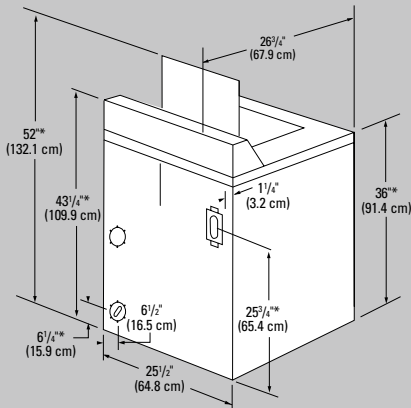

* Dimensions will vary according to adjustment of leveling legs; add 1/2" (1.3 cm) minimum.

OUR COMMITMENT TO DEPENDABLE QUALITY

At Maytag, we believe durable goods should remain just that. That's why every Maytag® product is constructed of the highest-quality materials and with the utmost in precision craftsmanship. It's also why we stand behind our equipment with solid service and support from our professional Maytag laundry suppliers. Simply put, when you choose Maytag® products, you ensure your peace of mind.



Energy Advantage™ Top-Load Washer	
WASHER SPECIFICATIONS	
MODEL	MAT12PRL
MOTOR	
Single-phase, reversible, thermoprotected	•
HP (kw)	1/2 (.37)
APPROXIMATE WATER USAGE — gal. (liters)	
Average hot water usage	2.8 (10.6)*
Average total water usage	23.5 (90)*
ELECTRICAL RATING	
Export model	120V, 60 Hz
FUSE REQUIREMENT	
Domestic model — amps	15
Export model — amps	10
CAPACITY	
Volume — cu. ft. (liters)	2 1/2 (70.8)
Diameter — in. (cm)	20 1/2 (52.1)
Depth — in. (cm)	13 (33.1)
LID OPENING	
In. (cm)	16 (40.6)
EXTRACT SPEED	
Maximum rpm	618
Maximum g-force	110
WATER PRESSURE	
Psi (bar)	15 – 120 Psi (1 – 8)
INLET HOSE LENGTH	
Ft. (m)	4 (1.22)
DRAIN HOSE LENGTH	
Ft. (m)	4 (1.22)
ADJUSTABLE LEVELING LEGS	
	•
COLOR	
White	•
APPROXIMATE WEIGHT	
Crated — lbs. (kg)	224 (102)
Uncrated — lbs. (kg)	198 (90)
* Average based on J1 testing with factory preset cycles.	
Flush-to-wall installation is permitted by a 1 1/4" (3.2 cm) back panel overhang.	
See specific instructions for proper installation. Because of continuous product improvement, Maytag reserves the right to change specifications without notice.	



NEW YORK CITY
M.E.A.

