



MAYTAG® COMMERCIAL NEPTUNE® HIGH-EFFICIENCY WASHER

MAH21PR



**THE BEST WARRANTY
IN THE BUSINESS —
5 YEARS ON ALL PARTS.**

OUR FASTEST-SELLING WASHER

Maytag® Commercial Neptune® high-efficiency washers use less water and energy than conventional washers, cutting your utility costs to increase your profits.

DEBIT CARD-READY

In addition to eliminating hassles with coins, debit card systems greatly reduce the likelihood of machine vandalism. Maytag® Computer Trac® controls are simple to operate and offer Super Cycle options for increased revenue.



FOR YOUR CUSTOMERS:

- No Need To Carry Quarters
- High-Speed Extraction Cuts Drying Time
- No-Agitator Design Increases Capacity
- Simple One-Touch Cycle Selection
- Display Counts Down Time Remaining
- Extra-Large Door Opens 180°
- Automatic Detergent, Softener And Bleach Dispenser
- Meets ADA Accessibility Guidelines

FOR YOUR OPERATION:

- Simple Soft-Mount Design
- Easy-To-Use Service Diagnostics
- Reversible Door
- Optional Audit System
- Ability To Set Vend Prices In Penny Increments

BUILT-TO-LAST™ FEATURES:

- Porcelain-Enamel Top
- Precision Endurance Drive
- Controlled Induction Motor



**SAVE UP TO
50% OR MORE
EVERY YEAR* ON ENERGY,
WATER AND SEWER COSTS.**

* Based on testing with a 10-pound AHAM load with 30% hot-, 55% warm- and 15% cold-water wash at five turns per day and 365 days per year. Water, gas and sewer costs based on 2000 average U.S. national rates. Individual savings may vary.

LAUNDRY SOLUTIONS YOU CAN *DEPEND* ON.

CLP647

Neptune® High-Efficiency Washer — DEBIT CARD-READY

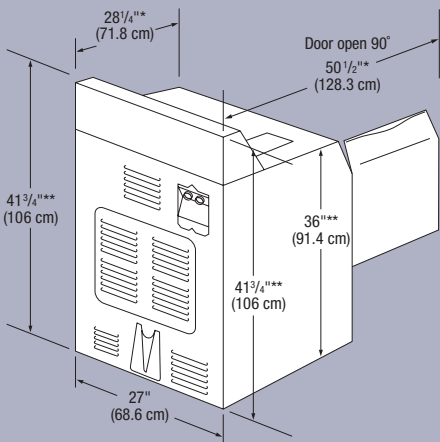

* Includes hinge on back of washer.

** Dimensions will vary according to adjustment of leveling legs; add 2" (5.1 cm) minimum.



5 YEARS — ALL PARTS

For a period from the date of original purchase through the time listed above, the designated parts that fail in normal commercial use will be repaired or replaced free of charge for the part itself, with the owner paying all other costs, including labor, transportation and customs duty. Chemical damage is excluded from all warranty coverage. See complete warranty for details.



Neptune® High-Efficiency Washer	
WASHER SPECIFICATIONS	
MODEL	MAH21PR 
MOTOR	
Variable-speed, reversible, thermoprotected, high-efficiency, controlled induction	•
Wash — HP (kw)	.25 (.19)
Extract — HP (kw)	.5 (.37)
APPROXIMATE WATER USAGE	
Hot-water cycle — gal. (liters)	5.5 (18.9)
Warm-water cycle — gal. (liters)	2 (9.5)
Overall — gal. (liters)	15 (56.7) [†]
ELECTRICAL RATING	
120V, 50/60 Hz	•
Export models — 240V, 50 Hz and 100V, 50/60 Hz	•
FUSE REQUIREMENT	
Amps	15
CYLINDER	
Volume — cu. ft. (liters)	2.9 (82.1)
Diameter — in. (cm)	21 1/2 (54.6)
Depth — in. (cm)	16 (40.6)
DOOR OPENING	
In. (cm)	15 1/2 (39.4)
WASH SPEED	
Maximum rpm	47 – 51
EXTRACT SPEED	
Maximum rpm	1,000
Maximum g-force	307
OPERATING PRESSURE	
Psi (bar)	15 – 120 (1 – 8)
INLET HOSE	
Ft. (m)	4 (1.22)
DRAIN HOSE	
In. (cm)	42 (109.7)
ADJUSTABLE LEVELING LEGS	
	•
COLOR	
White	•
APPROXIMATE WEIGHT	
Crated — lbs. (kg)	225 (102)
Uncrated — lbs. (kg)	195 (88)
[†] Average based on testing with an 8-pound AHAM load. If optional additional rinse is used, add 5 gallons; not dependent on incoming pressure or time.	
See specific instructions for proper installation. Because of continuous product improvement, Maytag reserves the right to change specifications without notice.	



NEW YORK CITY
M.E.A.

