



# MAYTAG® COMMERCIAL DEPENDABLE CARE® MULTI-LOAD STACK DRYER

## MLG32PDB



**THE BEST WARRANTY  
IN THE BUSINESS —  
5 YEARS ON ALL PARTS.**

### BUILT LIKE A TANK

The MLG32PDB is one of the heaviest 30-pound stack dryers on the market, offering years of dependable Maytag performance.

### MICROPROCESSOR CONTROLS

Maytag® Computer Trac® controls let you adjust prices by cycle, day and time — and they provide simple one-touch cycle selection.



### FOR YOUR CUSTOMERS:

- Fast-Drying Axial Airflow System
- ThermoGuard™ System Helps Prevent Laundry Overheating
- Extra-Large Door Openings
- Digital Display Shows Time Remaining In Cycle

### FOR YOUR OPERATION:

- Single Coin Box For Both Dryers
- Front Access For Easy Service
- One 8" Vent For Easy Installation
- 2 Large-Capacity Lint Drawers

### BUILT-TO-LAST® FEATURES:

- Heavy-Duty Enclosed Motors
- Permanently Lubricated Bearings
- Rear Belt Drive System
- The Best Warranty In The Business



*Model MLG32PDB  
shown in White.*



*Model MLG32PDB  
shown in Stainless  
Steel.*

LAUNDRY SOLUTIONS YOU CAN **DEPEND** ON.

## Dependable Care® Multi-Load Stack Dryer — MICROPROCESSOR COIN-DROP

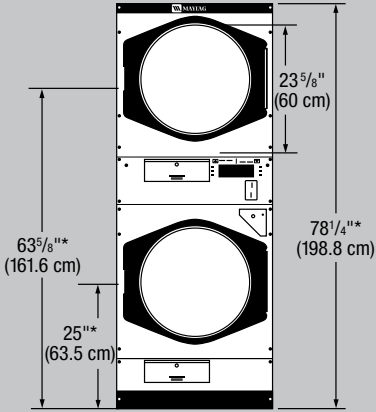

FRONT VIEW

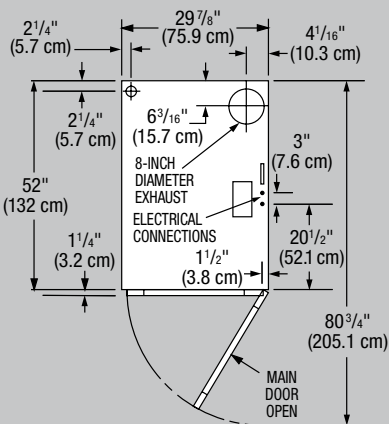

TOP VIEW

\*Dimensions will vary according to adjustment of leveling legs; add 1/2" (1.3 cm) minimum.

		Dependable Care® Multi-Load Stack Dryer
<b>DRYER SPECIFICATIONS</b>		
<b>MODEL</b>	<b>MLG32PDB</b>	
<b>MOTOR</b>		
Single-phase, thermoprotected against overload, auto-reset	•	
HP (kw)	1/2 (.373)	
<b>CAPACITY</b>		
Lbs. (kg) per drying chamber	30 (13.6)	
Cu. ft. (cu. m) per drying chamber	10.1 (.287)	
<b>AIRFLOW</b>		
Cfm (cmm) per drying chamber	420 (11.9)	
<b>TUMBLERS</b>		
Diameter — in. (cm)	27 1/4 (69.2)	
Depth — in. (cm)	30 (76.2)	
<b>DOOR OPENING DIAMETER</b>		
In. (cm)	21 1/2 (54.6)	
<b>ELECTRICAL REQUIREMENTS</b>		
<b>BREAKER/FUSE REQUIREMENTS</b>		
Amperes per drying chamber	20	
<b>EXHAUST DUCT DIAMETER</b>		
In. (cm)	8 (20.3)	
<b>GAS RATING</b>		
BTU/hr. (kcal/hr.) per drying chamber	80,000 (20,160)	
<b>GAS INLET</b>		
In. (cm)	3/4 (1.9)	
<b>ADJUSTABLE LEVELING LEGS</b>	•	
<b>COLORS</b>	•	
White	•	
Bisque	•	
Stainless Steel	•	
<b>APPROXIMATE WEIGHT</b>		
Crated — lbs. (kg)	915 (415)	
Uncrated — lbs. (kg)	875 (397)	
See specific instructions for proper installation. Because of continuous product improvement, Maytag reserves the right to change specifications without notice.		



NEW YORK CITY  
M.E.A.



### 5 YEARS\* — ALL PARTS

For a period from the date of original purchase through the time listed above, the designated parts that fail in normal commercial use will be repaired or replaced free of charge for the part itself, with the owner paying all other costs, including labor, transportation and customs duty. Chemical damage is excluded from all warranty coverage. See complete warranty for details.

\* This limited-time Maytag® Extra-Protection 5-Year Warranty offer is available through December 31, 2004.

